



Sentry Level Monitor



Up to four programmable 10A SPST alarm relay outputs

Four digit LCD display

Advanced microprocessor retains programmed values even with power interruption

AC input 90-250 VAC

+24V for sensor operation

Programmable scale and offset

NEMA 4X enclosure

Outputs can be programmed for Hysterisis and Averaging

Transparent lid allows direct observation of measured process value

Can be used to monitor open channel flow such as across a weir

The Sentry Level Monitor is designed to provide a low cost solution for liquid level control and monitor applications. Either a pressure sensor (PS1) or an ultrasonic sensor (SR3,6,12, 25, or 35) can be connected to the SLM and the SLM can be programmed to operate up to four alarm relays to control pumps, valves, motors, or alarm indicators.

The input of the SLM is designed to accept a current loop (4-20mA) process signal. While the SLM will operate fine with the PS1 pressure sensor or the Sonarange ultrasonic sensors, other two wire or three wire current loop sensors could also be used.

Each input can be scaled to select units meaningful to the particular application.

The Sentry Level Monitor is designed to be a stand-alone economical means of easy liquid level monitoring.

The Sentry liquid level monitor equipped with either a pressure sensor or an ultrasonic sensor is one of the quickest ways to start monitoring almost any liquid level.



Engineering and Manufacturing Services
47745—193rd St. Toronto, SD 57268 USA
(P) (605) 794-2072 (F) (605) 794-2073 emssensors.com

Theory of Operation

The Sentry Level Monitor operates by measuring an input signal from a pressure or ultrasonic sensor and comparing the measurement with programmed setpoints and then operating up to four output alarm relays if needed. The Sentry Level Monitor can be powered from 90-250VAC and supplies +24VDC for sensor operation.

Programming is the key to configuring the Sentry Level Monitor. There are two main programming options, The inputs and the outputs. The programming flow chart more fully describes these functions.

The Sentry Level Monitor can be configured with up to four alarm relay outputs. Each alarm relay has an LED to indicate when the relay has been operated.

The Sentry Level Monitor continuously measures the liquid level information from the sensor and converts this information into units meaningful to the application. The Sentry Level Monitor updates the display with this information and uses this information to set or release alarm relays.

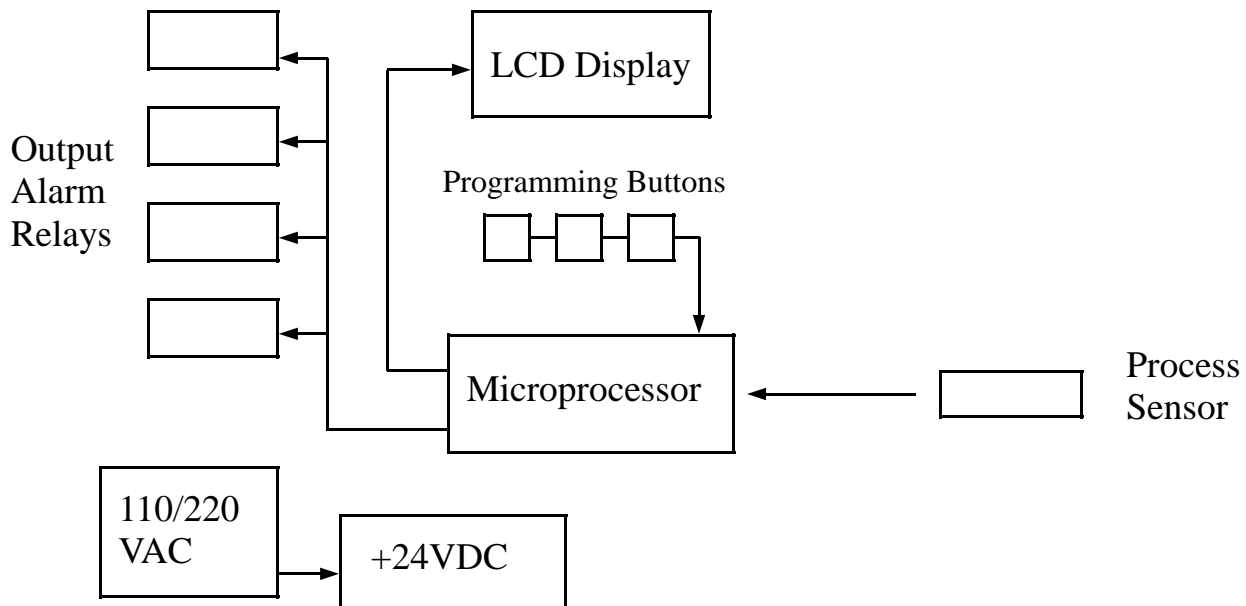

The Sentry Level Monitor makes measurements of input channel conditions about every half second. An averaging option exists in software to allow the measurements to be smoothed out over time. Programming options provide for selection of alarm delay and recovery options that allow each alarm channel to be selected for a specific operate and release condition.

Typical Applications

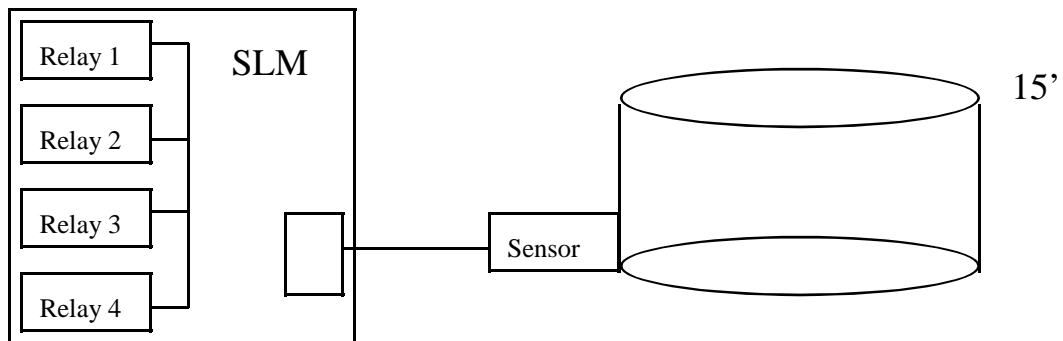

A pressure sensor shown with a Sentry Level Monitor equipped with four set-point relays. Because the liquid level does not go up to 30', the full 15 PSI range of the sensor would not be used. This would result in a 4- to approximately 12mA signal that the SLM would scale into the appropriate units.

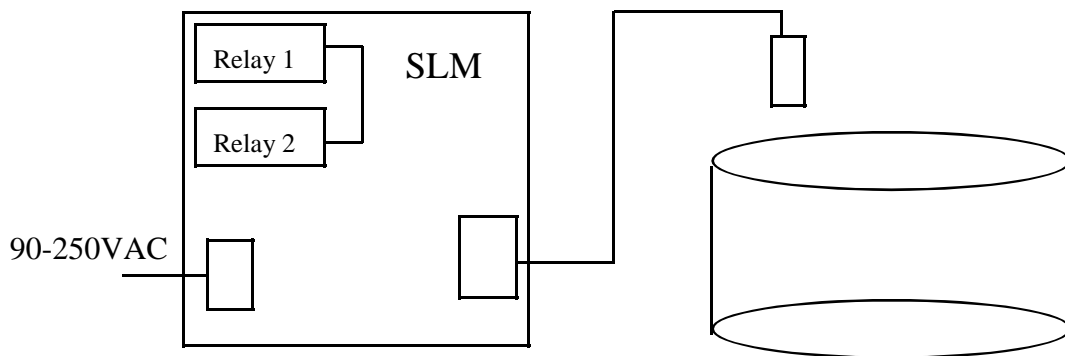

An ultrasonic sensor shown with a Sentry Level Monitor equipped with two alarm relays. The AC power connection is also shown. Unshown are the two pin terminal blocks for each alarm relay. Each relay can be programmed to operate or release upon an alarm condition. For ultrasonic applications, the sensor should be selected to cover the full distance of the liquid level height.

Programming quick reference sheet

Left most digit shows the program step

Programming buttons

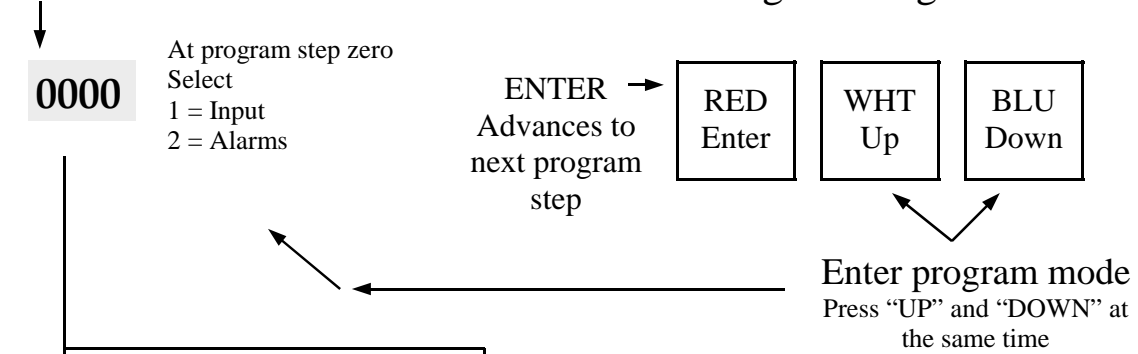

| Input | | Alarms | |
|-------------|---|-------------|---|
| 1000 | Step 1 Decimal point 1 = XX.X 2 = X.XX 3 = .XXX | 1000 | Step 1 Alarm select 1,2,3,4 |
| 2000 | Step 2 LV scale factor 000-999 | 2000 | Step 2 Setpoint 000-999 |
| 3000 | Step 3 LS scale factor 000-999 | 3000 | Step 3 Over / under 0 = under 1 = over |
| 4000 | Step 4 HV scale factor 000-999 | 4000 | Step 4 Alarm delay 0-30 seconds |
| 5000 | Step 5 HS scale factor 000-999 | 5000 | Step 5 Recover delay 0-30 seconds |
| | | 6000 | Step 6 Hysterisis 0-30 counts |
| | | 7000 | Step 7 Averaging 0-30 counts |

When the last "ENTER" is pressed in a programming series, the operating mode is automatically entered

Programming

The programming mode can be entered into at any point the unit is powered up. Care should be taken if the unit is connected to an existing process that interruption of the monitoring process does not cause a potential problem for safety or a problem with the process.

The program mode is entered by pressing both the white (up) and blue (down) buttons at the same time. The display will show all zeros and the blue or white buttons can be pressed to select options 1 (input channel programming) or 2 (output alarm programming). Pressing the red (enter) button accepts the selected value and moves to the next program state.

Use the UP and DOWN buttons to select the program value and press ENTER to save the value and advance to the next program step.

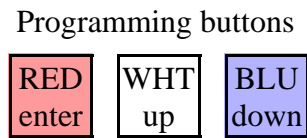

Enter the program mode by pressing the UP and DOWN buttons at the same time

Decimal Points

Because the measured sensor signal (process variable) is scaled, the display needs to know where to put a decimal point. This is selected for the ease of use of the operator or installer to aid in seeing the scaled process valued displayed in terms meaningful to the application.

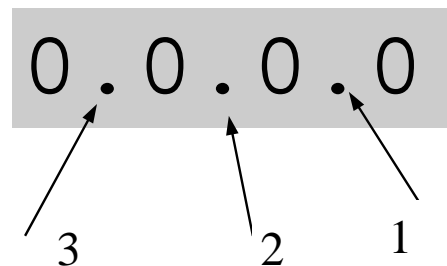

If a 15' tank were to hold 500 gallons, the maximum amount displayed would be 500. A "0" would be selected for the display because the measurements would be scaled to read from 000 to 500.

In this application a 4-20mA pressure sensor (1/2 range at 15') would be scaled so that 4mA was set to equal zero and 12mA was set to equal 500 (500).

The full four digits of resolution are not used because the setpoint can only be programmed using three digits.

Scaling

Because the Sentry Level Monitor can be used in so many different applications, the display can be configured to display almost any units needed. Scaling is the means to “translate” the sensor information into the user defined display information.

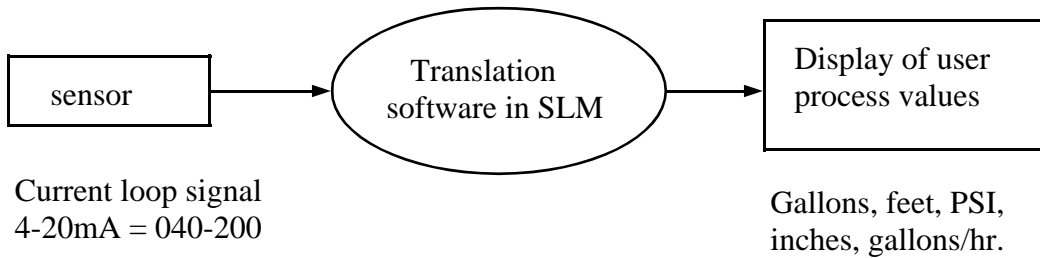

Scale values

In order to program the Sentry Level Monitor to scale the sensor information into the proper process values, four numbers need to be selected. The first two numbers need to be some range of the sensor output. For a 4-20 mA sensor the maximum range of output would be 040-200 (the full range does not have to be used). The range can be selected by specifying the lowest and highest values (040 and 200) or a segment of the range can be selected (i.e. 080 and 150).

Once the two sensor values have been selected, the next step is to select two corresponding process values.

High and low sensor values

High and low process scale values

| | | | | |
|----|-----|---|-----|----|
| LV | 040 | = | 000 | LS |
| HV | 200 | = | 999 | HS |

The example above could be used if the full range of a 4-20 mA pressure sensor was used to measure the fluid in a 0-1000 gallon tank.

Process values

Once the Sentry Process Monitor has been programmed to translate the sensor values into user process values, the output can be programmed using these values. For example, if it is desired to turn a pump on or off when a certain number of gallons are reached, the SLM can be programmed in gallons instead of having to convert the sensor value each time.

The display will be meaningful to the user because the values will be displayed in terms of the process they are running

Output Alarm Programming

Alarm channel selection

Once the output alarm program option has been selected, the next programming option is to select which output alarm will be programmed. There can be up to four output alarms. Programming unequipped output alarms should result in no undetermined conditions since there are no relays to operate.

Setpoint Programming

A value is selected (using the up and down buttons) against which the assigned input will be compared. Whatever units were selected to scale the input are the same units that are used to set the alarms.

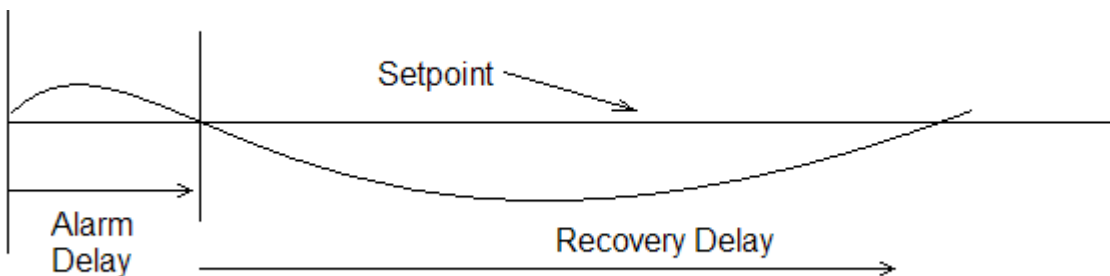

Over / Under programming

The next selection is to decide if the output alarm relay should operate if the measured value is over or under the selected setpoint value. A “1” is selected if an over condition and a “0” is selected for an under condition.

Alarm Delay Programming

The next value to be selected is the alarm delay. Some process operations require a tolerance of brief alarm conditions such as the start up of pump, motor, or other mechanical processes. A delay of from 0-30 seconds can be selected to accommodate brief alarm conditions without actually operating the alarm relay.

Recovery Delay Programming

Similar to the alarm delay, the recovery delay can be selected from 0-30 seconds to establish the time before a “return to normal” condition is accepted.

WARNING - Extreme care needs to be taken when selecting these values so that operation of machinery will not occur that might cause harm to personnel

Hysterisis Programming

Hysterisis is the amount above and below the setpoint that the input has to change before the output alarm relay will be effected. It can be selected from 0-30. A value of thirty means that an input condition has to reach the setpoint plus (or minus) thirty units before the alarm condition can be removed. This is useful in cases where the input can very close to the setpoint to avoid relay “chatter”.

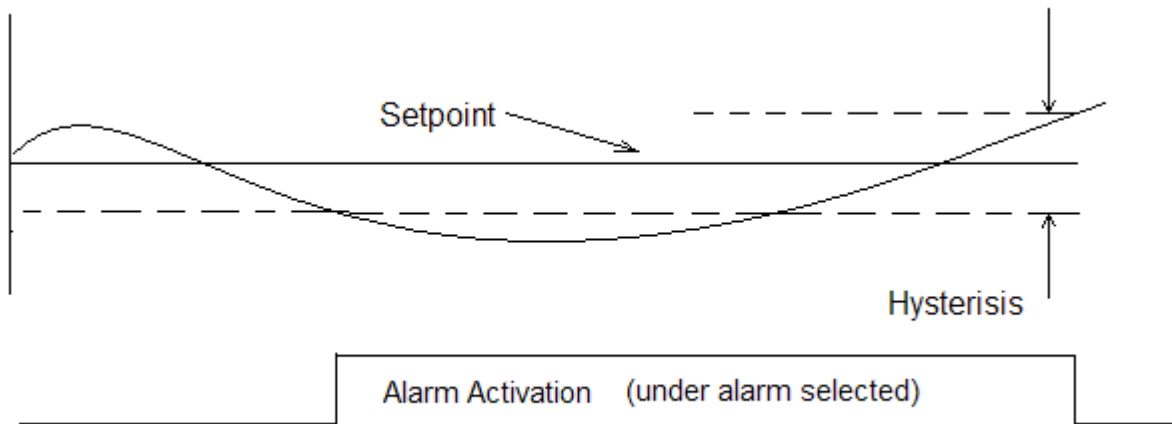

Averaging

The output alarm can be programmed to average the measured input value from 0-30 samples. This is a rolling average of the last “X” number of measurements. This can be useful to make erratic measurements more consistent. However, it does slow down the ability to respond to sudden input changes.

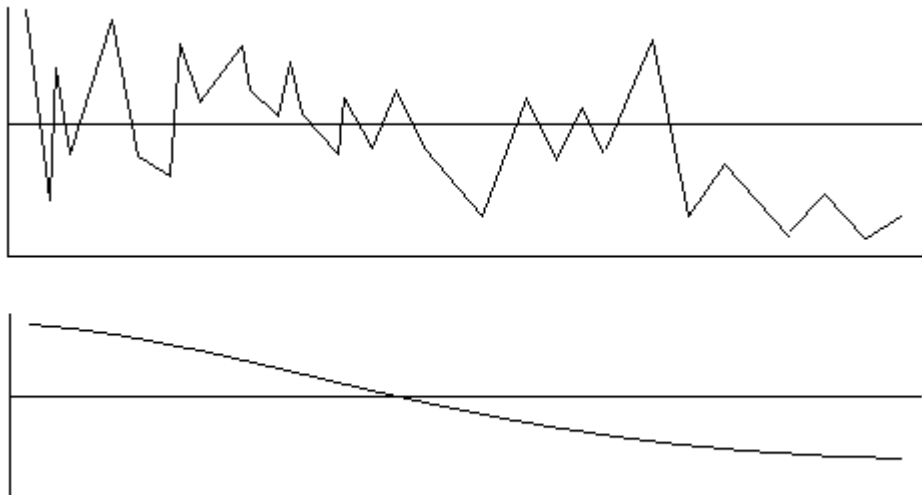

Wiring

Current Loop

Current loop sensors can be as diverse as 0-20ma, 4-20ma, 20-0ma, 20-4ma, or two wire and three wire (current sourcing) devices. The scaling portion of input channel programming provides for signal inversion or offset if needed.

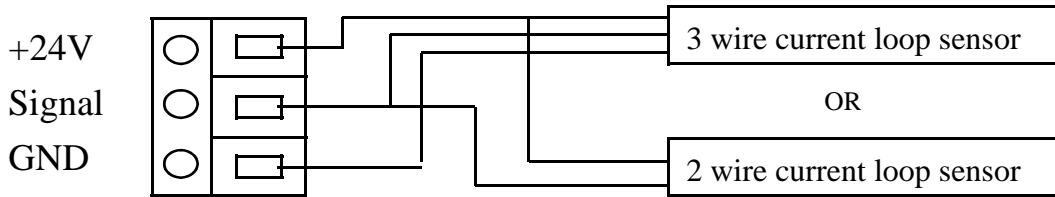

Input channel terminal block

Care needs to be taken so as to not put +24V into the signal input. This is connected directly to the microprocessor and can result in damage to the SLM.

Power wiring

The AC input power wiring requires a single phase (two wire) input of 90-250VAC and a ground connection

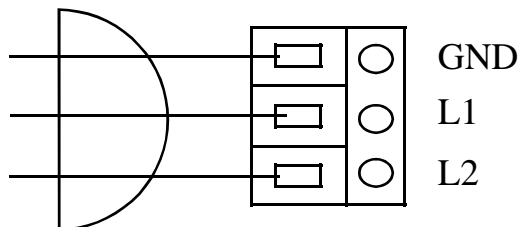

Any wiring needs to be performed by qualified personnel and in accordance with all applicable regulations and procedures.

Sensor Shield Wiring

Most applications do not need to make use of an earth ground connection to shield wires for the sensor cables. However, if this type of connection is required, it is available below the channel input terminal block.

There is no provision for connection of AC voltage to any of the terminals on the right side of the Sentry Level Monitor. Such connections will cause damage to the unit and possibly cause exposure of hazardous voltages to personnel.

Care should be taken in wiring not to put wrong DC voltages to input channel terminal block pins as this also can result in equipment failure.

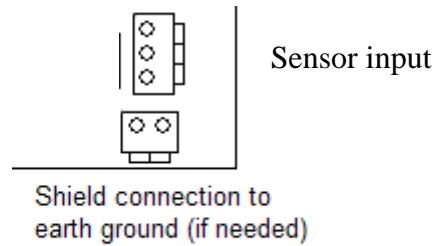

Enclosure dimensions

Consideration should be given to the final dimensions including conduit fittings and cable glands.

A mounting kit is available with a bracket to provide for installation where it is preferred not to mount the unit directly to equipment.

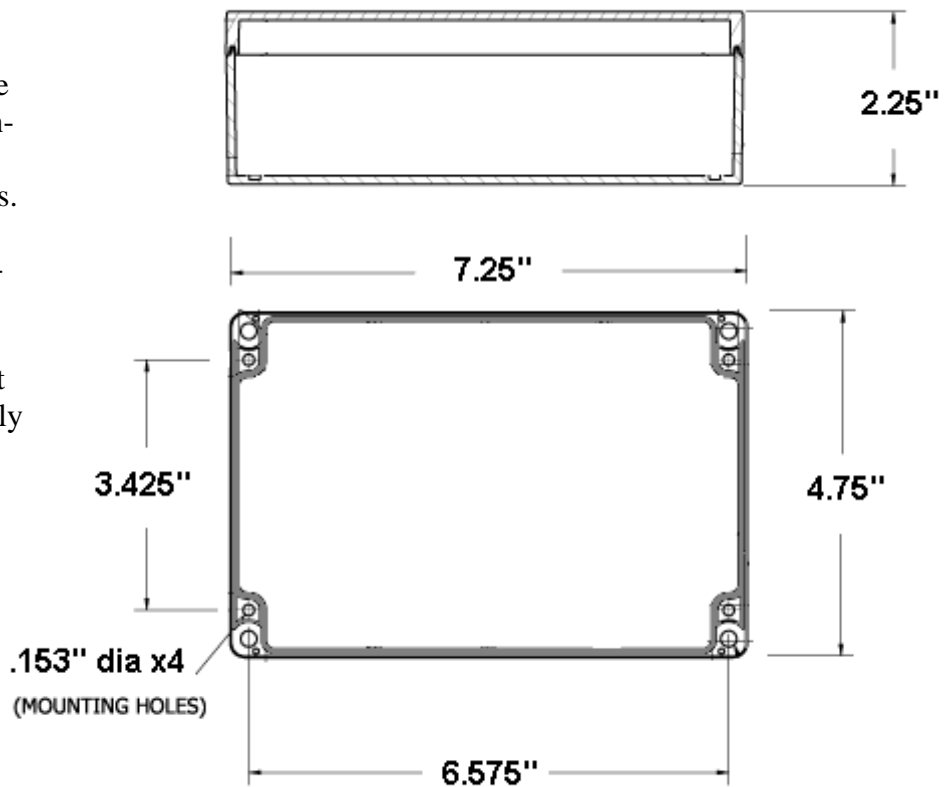

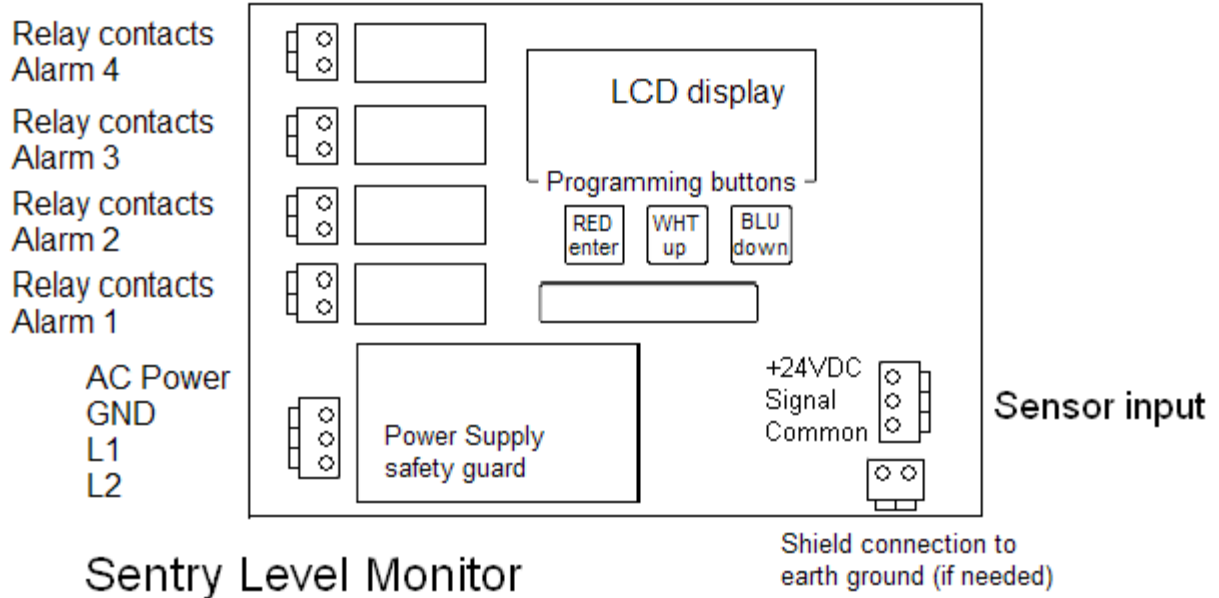

Specifications:

Input Voltage: 90-250VAC

Output Voltage (sensors): +24VDC

Output Relays: SPST 10A NO

Accuracy : +/- 1% (scale and offset can often be used to recalibrate to better specs)

Analog Measurements:

0-20mA

Enclosure

NEMA 4X

Installation

Because the Sentry Level Monitor can be configured in a variety of ways and because the possible connection to hazardous voltages, the Sentry Level Monitor should only be installed by qualified personnel and in accordance with all applicable building and wiring codes and regulations. In addition, the Sentry Level Monitor should not be as a sole element in a critical, safety, or life dependent application. Such applications should always be designed with redundancy to account for equipment failure, misapplication, or operator error.

Warning

Improper installation can result in hazardous voltages and / or machinery operation. Installation should only be performed by qualified personnel and in accordance with all safety and regulatory procedures.

Power Wiring

The earth ground should not be left disconnected. This connection is passed along to the sensor input side of the Sentry Process Monitor. It can be used for sensor shield connection (if required) to reduce electrical noise that may interfere with proper signal transmission. If this connection is inadvertently wired to L1 or L2 of the input power, damage to equipment and electrical shock to personnel can result.

It is a good practice to use a contactor or other device to remove power until a manual reset in the event of power loss. The connection of pumps, motors, or other active devices to the alarm relays can result in a safety hazard if power is returned unexpectedly or if power returns intermittently.

Enclosure integrity

The Sentry Level Monitor has a water and dust tight enclosure. However, the installation of conduit fittings can reduce the effectiveness of the enclosure. If it is desired to retain the water and dust protection, electrical fittings need to be selected and installed to accomplish this. Allowing water or other material to enter the Sentry Process Monitor can result in equipment failure and even danger to personnel. Condensation cycling should be avoided to prevent equipment damage.

The plastic of the enclosure is subject to breakage with larger size drills. For this reason it is recommended that conduit holes be bored out with a conical rasp, reamer, or step drill to insure that the correct hole size is obtained with a minimum risk of damage to the enclosure.

Power supply safety shield

The clear plastic shield over the power supply should not be removed. It prevents operators from contacting the input voltage and removal could result in electrical shock. This cover should not be removed. If the cover is missing or broken, the unit should be returned for repair.

Enclosure cover

The Sentry Process Monitor is shipped with a clear plastic enclosure cover. This should only be removed for programming and installation purposes. The cover allows the display values to be observed, but protects the electronics from foreign objects which could cause damage. Personnel are also protected from exposure to electrical shock by keeping the enclosure cover installed. A missing or broken cover should be replaced to insure safety and protect the equipment from damage.

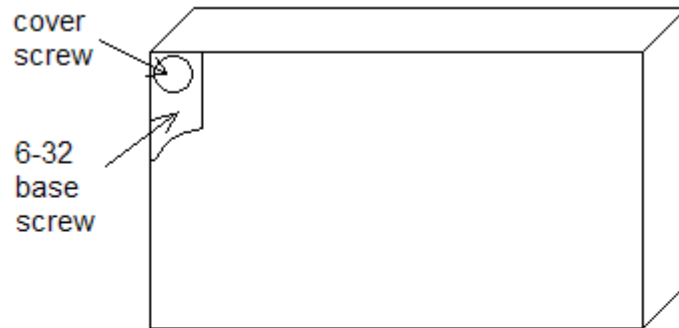

Mounting Hole Pattern

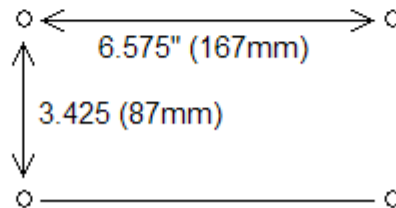

An aluminum mounting kit is available (with screws) - see appendix

Part Numbers

Sentry Process Monitor basic one alarm relay SPM—1

Sentry Process Monitor two alarm relays SPM—2

Sentry Process Monitor three alarm relays SPM—3

Sentry Process Monitor four alarm relays SPM—4

Accessories

Mounting kit with hardware SPM-MTGK

PG7 cable gland (.5" dia. mtg. hole) .12-.26 cable dia. SPM-CG7

PG11 cable gland (.75" dia. mtg. hole) .2-.39 cable dia. SPM-CG11

Replacement enclosure

Caution

The Sentry Level Monitor is used in conjunction with sensors and other devices. Total system performance is dependent upon these components as well as the programming and scale factors. Since there are so many programming options, each application needs to be tested during installation to make sure that the Sentry Level Monitor works with all application conditions. This testing is essential. In addition, the Sentry Level Monitor should not be used as a sole element in any safety, critical process, or life dependent application. These applications should always be designed with redundancy.